

12VDC or 12V battery

Chassis

DC/DC

Fuseholder Resistor
200/200V

Main Contactor

Diode 200V/3A

FUSE 2A

Battery Pack

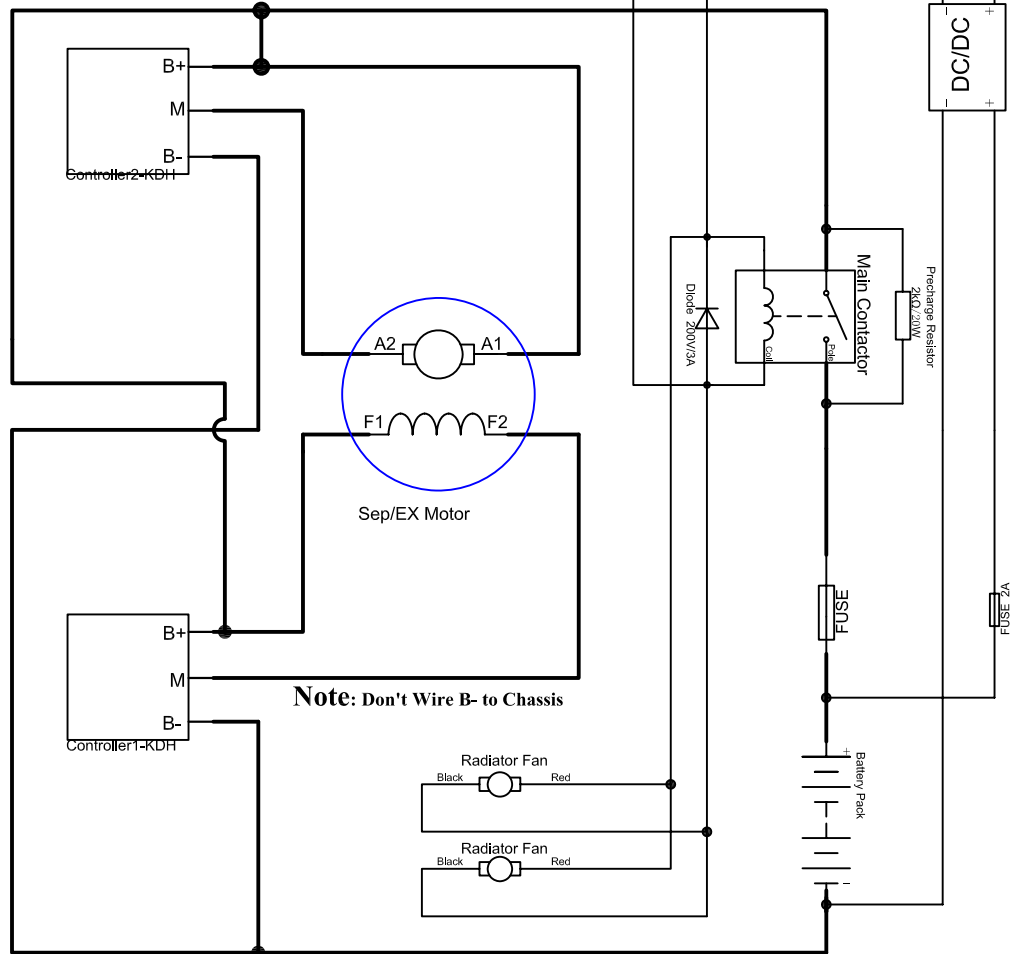

Note: Don't Wire B- to Chassis

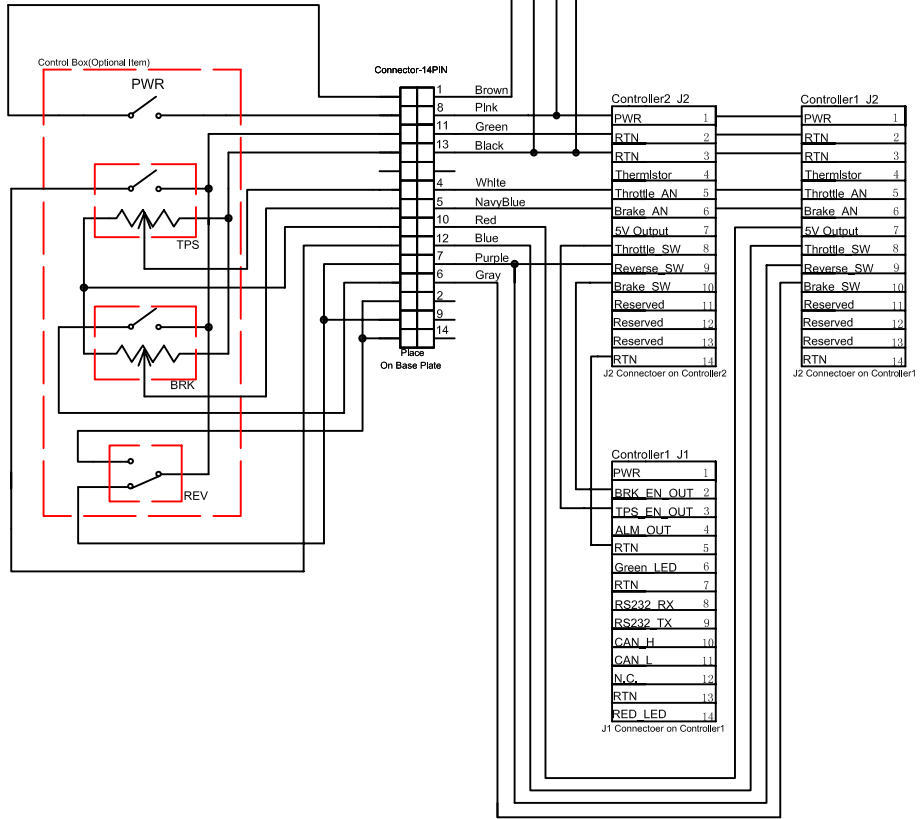

Connector-14PIN

Controller2 J2

Controller1 J2

Controller1 J1

J1 Connector on Controller1

J2 Connector on Controller2

J2 Connector on Controller1

Place On Base Plate

See From Front Side

	1	2	3	4	5	6	7	
	Brown From battery			White TPS	NavyBlue Brake_AN	Gray Brake_SW	Purple Reverse_SW	
	8	9	10	11	12	13	14	
	Pink PWR		Red 5V output	Green SW Common	Blue Throttle SW	Black RTN		

14PIN Connector

Dual KDH Controller Assembly Wiring Diagram

							KELLY CONTROLS, LLC		
Mark	Subarea	Signatory	Date	06/19/2009					
Design		Stand		modification	Number	Proportion			
Assessor									
Technics	Authorize								
							Sum		